

CURRENT TRANSFORMER

Model 780

Window Diameter 6.5"

Application:
Relaying and Metering

Frequency:
50 - 400 Hz

Insulation Level:
600 Volts, 10 kv BIL full wave

Continuous Thermal Current Rating Factor:

50:5 thru 1200:5 2.0 at 30°C amb., 1.5 at 55°C amb.
1500:5 thru 4000:5 1.5 at 30°C amb., 1.33 at 55°C amb.

- Secondary terminals are No. 10 - 32 brass screws with one flatwasher, lockwasher and regular nut.

- Approximate weight: 30 lbs.



E228202

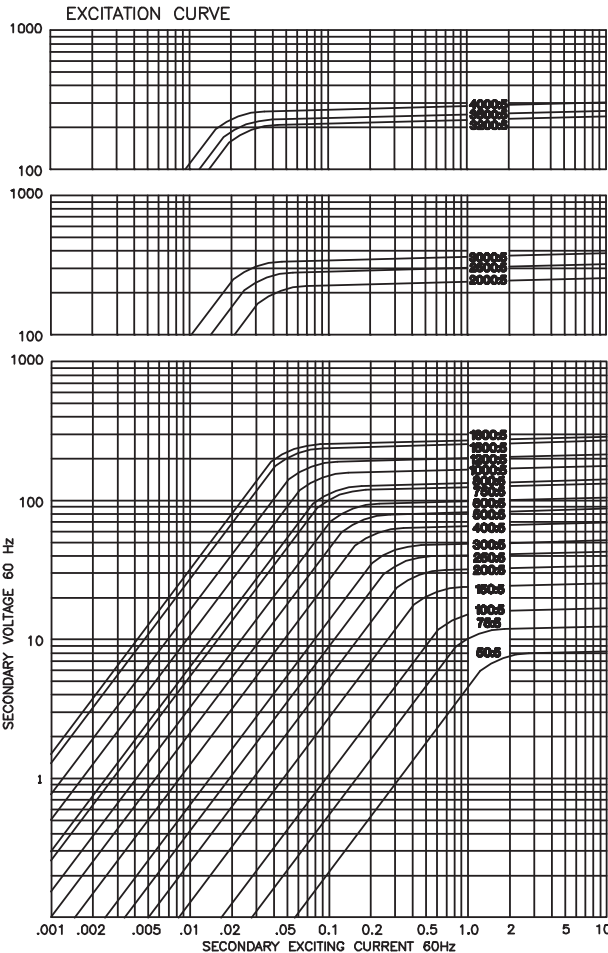
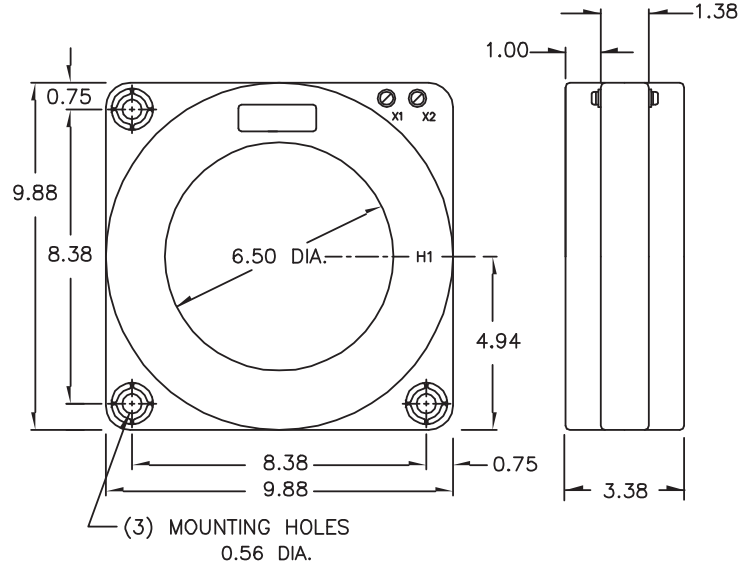
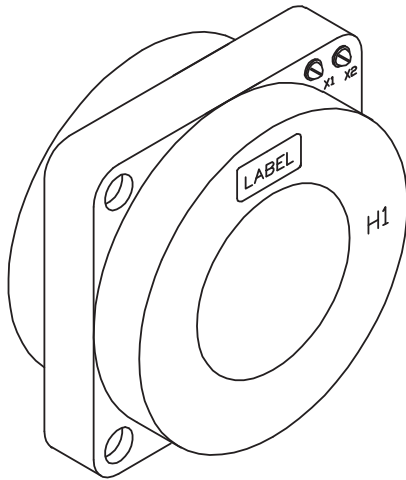

CATALOG NUMBER	CURRENT RATIO	RELAY CLASS	ANSI METERING CLASS AT 60 Hz					SECONDARY WINDING RESISTANCE (OHMS @ 75°C)
			B0.1	B0.2	B0.5	B0.9	B1.8	
780-500	50:5	-	4.8	-	-	-	-	0.008
780-750	75:5	C 10	4.8	4.8	-	-	-	0.016
780-101	100:5	C 10	1.2	1.2	4.8	-	-	0.027
780-151	150:5 *	C 20	0.6	0.6	2.4	2.4	4.8	0.042
780-201	200:5 *	C 20	0.6	0.6	1.2	2.4	4.8	0.054
780-251	250:5 *	C 20	0.6	0.6	0.6	1.2	2.4	0.067
780-301	300:5 *	C 20	0.3	0.6	0.6	1.2	2.4	0.097
780-401	400:5 *	C 50	0.3	0.3	0.3	0.6	1.2	0.129
780-501	500:5 *	C 50	0.3	0.3	0.3	0.6	0.6	0.161
780-601	600:5 *	C100	0.3	0.3	0.3	0.3	0.6	0.193
780-751	750:5 *	C100	0.3	0.3	0.3	0.3	0.3	0.242
780-801	800:5 *	C100	0.3	0.3	0.3	0.3	0.3	0.258
780-102	1000:5 *	C100	0.3	0.3	0.3	0.3	0.3	0.322
780-122	1200:5 *	C200	0.3	0.3	0.3	0.3	0.3	0.387
780-152	1500:5 *	C200	0.3	0.3	0.3	0.3	0.3	0.608
780-162	1600:5 *	C200	0.3	0.3	0.3	0.3	0.3	0.649
780-202	2000:5 *	C200	0.3	0.3	0.3	0.3	0.3	0.588
780-252	2500:5 *	C200	0.3	0.3	0.3	0.3	0.3	0.735
780-302	3000:5 *	C200	0.3	0.3	0.3	0.3	0.3	1.105
780-322	3200:5 *	C100	0.3	0.3	0.3	0.3	0.3	0.859
780-352	3500:5 *	C100	0.3	0.3	0.3	0.3	0.3	0.940
780-402	4000:5 *	C200	0.3	0.3	0.3	0.3	0.3	1.074